

A Complete Analysis of Resultants and Extraneous Factors for Unmixed Bivariate Polynomial Systems using the Dixon formulation *

Arthur Chtcherba

Deepak Kapur

Department of Computer Science
University of New Mexico
Albuquerque, NM 87131
e-mail: {artas,kapur}@cs.unm.edu

December, 2001

Abstract

A necessary and sufficient condition on the support of a generic unmixed bivariate polynomial system is identified such that for polynomial systems with such support, the Dixon resultant formulation produces their resultants. It is shown that Sylvester-type matrices can also be obtained for such polynomial systems. These results are shown to be a generalization of related results recently reported by Zhang and Goldman. The concept of the interior of a support is introduced; a generic inclusion of terms corresponding to support interior points in a polynomial system does not affect the nature of the projection operator computed by the Dixon construction. For a support not satisfying the above condition, the degree of the extraneous factor in the projection operator computed by the Dixon formulation is calculated by analyzing how much the support deviates from a related support satisfying the condition.

For generic mixed bivariate systems, "good" Sylvester type matrices can be constructed by solving an optimization problem on their supports. The determinant of such a matrix gives a projection operator with a low degree extraneous factor. The results are illustrated on a variety of examples.

1 Introduction

New results characterizing generic unmixed polynomial systems with two variables for which resultants can be exactly computed and Sylvester-type matrices can be constructed are proved. Earlier in [CK00a], Chtcherba and Kapur had shown that the support of a bivariate unmixed polynomial system not including an orderable simplex is a necessary and sufficient condition for the determinant of the associated Dixon matrix being exact resultant (without any extraneous factors). Independently, Zhang and Goldman [ZG00], as well as Zhang in his Ph.D. thesis [Zha00] proposed corner-cut supports for which Sylvester-type multiplier matrices can be constructed whose determinant is the exact resultant. These results are shown to be related. A necessary and sufficient condition on bivariate supports is identified such that for a generic unmixed polynomial system with such a support, its resultant can be computed exactly using a construction based on the Dixon resultant formulation. These bivariate supports are shown to include Zhang and Goldman's corner-cut supports. In addition, the proposed construction also provides insight into the degree of the extraneous factor in a projection operator computed from a Dixon multiplier matrix for bivariate polynomial systems whose support do not satisfy the proposed conditions.

The algorithm for constructing multiplier matrices based on the Dixon resultant formulation works in general for polynomial system from which more than two variables need to be eliminated even when the polynomial

*This research is supported in part by NSF grant nos. CCR-9996144, and CDA-9503064, and a grant from the Computer Science Research Institute at Sandia National Labs.

system is not necessarily unmixed. These multiplier matrices can be used to extract (in most cases) the resultants as determinants of their maximal minors. The approach generalizes a related method for constructing multiplier matrices from the Dixon resultant formulation discussed in a paper by Chtcherba and Kapur in RWCA'00. Beside being a generalization, the approach has the advantage of generating Sylvester-like multiplier matrices whose determinants are resultants even in cases where the earlier method by Chtcherba and Kapur produces an extraneous factor.

It is also shown that for the bivariate case that the proposed construction produces multiplier matrices with resultants as their determinants even in some mixed systems. The term in the support of polynomials in a polynomial system is selected by formulating an optimization problem that minimizes the size of the Dixon multiplier matrix. The approach is compared with other approaches, and is shown to be more efficient and to work better on many examples of practical interest.

For unmixed polynomial systems in which more than two variables are simultaneously eliminated, the determinant of the associated Dixon multiplier matrix is shown to be not necessarily the resultant even for corner-cut supports. Nevertheless preliminary results show that with proper generalization to polynomial systems with more variables, the results will hold in general.

Section 2 defines supports of a polynomial and a polynomial system, and reviews the BKK bound for toric roots and toric resultants of a polynomial system. Section 3 reviews the Dixon formulation of resultants, where the Dixon matrix and the Dixon polynomial of a given polynomial system are introduced. Section 4 analyzes the support of the Dixon polynomial in terms of the support of the polynomial system. It is shown that the support of the Dixon polynomial can be expressed as a union of the support of the Dixon polynomials of polynomial systems corresponding to simplexes. The concept of complement support characterizing how different a given support is from a bi-degree support (in the case of bivariate systems) is introduced; this support complement can be partitioned into four corners. It is shown that for a given polynomial system, the support of its Dixon polynomial (which determines the size of the Dixon matrix) can be shown to be a rectangular support from which the four corner support complement determined from the support of the polynomial system are removed. In that section, points inside the convex hull of the support of a polynomial system are classified into two categories: (i) *support interior* points such that when terms corresponding to these support points are included in the polynomial system, the support of the Dixon polynomial and hence, the size of the Dixon matrix does not change, (ii) other support points such that the corresponding terms when included in the polynomial system contribute to the extraneous factors in the projection operator computed from the associated Dixon matrix.

Section 5 includes the main results of the paper, where the size of the Dixon matrix is related to the BKK bound. It is shown that if a support of the polynomial system, after inclusion of its support interior points, is the same as a rectangular support with four rectangular corners removed, then the size of the Dixon matrix is the same as the BKK bound; this implies that for generic unmixed polynomial systems which such supports, the Dixon formulation computes the resultant exactly. For generic unmixed polynomial systems which supports do not satisfy this condition, it is shown how the degree of the extraneous factor can be precisely estimated. In Section 6, these results are extended to Dixon multiplier matrices, which are Sylvester type matrices but constructed using the Dixon formulation. Zhang and Goldman's results about corner cut supports are shown to be a special case of our results discussed in Sections 5 and 6. Section 7 considers mixed polynomial systems. It is first shown how some of the results from Sections 5 and 6 apply for a subclass of generic mixed polynomial systems as well. To generate "good" Dixon multiplier matrices whose determinants are projection operators with minimal degree extraneous factor, an optimization problem minimizing the support of the Dixon polynomial is formulated in terms of the term used to generate the Dixon multiplier matrix. An example illustrating this idea is discussed in detail. Section 8 compares our results experimentally with other approaches on a variety of examples.

2 Bivariate Systems

Consider a bivariate polynomial system \mathcal{F} ,

$$f_0 = \sum_{\alpha \in \mathcal{A}_0} a_{i,j} x^{\alpha_x} y^{\alpha_y}, \quad f_1 = \sum_{\beta \in \mathcal{A}_1} b_{i,j} x^{\beta_x} y^{\beta_y}, \quad f_2 = \sum_{\gamma \in \mathcal{A}_2} c_{i,j} x^{\gamma_x} y^{\gamma_y},$$

where for $i = 0, 1, 2$, each finite set \mathcal{A}_i of nonnegative integer tuples is called the *support* of the polynomial f_i ; it is denoted by $\mathcal{A}_i = S_{\mathbf{x}}(f_i)$. If $\mathcal{A}_0 = \mathcal{A}_1 = \mathcal{A}_2$, the polynomial system is called *unmixed*; otherwise, it is called *mixed*.

We will denote the support of a polynomial system \mathcal{F} by $\mathcal{A} = \langle \mathcal{A}_0, \mathcal{A}_1, \mathcal{A}_2 \rangle$. Given a support \mathcal{A}_i , let $\text{Vol}(\mathcal{A}_i)$ stand for the Euclidean volume of the convex hull of \mathcal{A}_i .

Theorem 2.1 (BKK) *Given two bivariate polynomials f_1, f_2 , with corresponding supports \mathcal{A}_1 and \mathcal{A}_2 , the number of common toric roots of these polynomials is either infinite or at most*

$$\mu(\mathcal{A}_1, \mathcal{A}_2) = \text{Vol}(\mathcal{A}_1 + \mathcal{A}_2) - \text{Vol}(\mathcal{A}_1) - \text{Vol}(\mathcal{A}_2);$$

further, for most choices of coefficients, this bound is exact.¹ The function μ is called the *mixed volume function* [GKZ94].

If $\mathcal{A}_1 = \mathcal{A}_2$, then $\mu(\mathcal{A}_1, \mathcal{A}_2) = 2\text{Vol}(\mathcal{A}_1)$.

The polynomial system $\{f_1, f_2\}$ is called *generic* if number of toric roots of any two polynomials equals to its BKK bound.

In a generic case, the toric resultant of $\mathcal{F} = \{f_0, f_1, f_2\}$ is of degree equal to the BKK bound in terms of the coefficients of remaining polynomial f_0 [PS93]. For example, the degree of the resultant in terms of coefficients of f_0 is $\mu(\mathcal{A}_1, \mathcal{A}_2)$.

Using the Sylvester dialytic method, one can construct the resultant matrix for a given polynomial system by multiplying each polynomial by a set of monomials, called its *multipliers*, and rewriting the resulting polynomial system in the matrix notation. Let $X_i = \{x^a y^b\}$, $i = 0, 1, 2$, be the multiplier set for the polynomial f_i , respectively; then the matrix is constructed as

$$\begin{pmatrix} X_0 f_0 \\ X_1 f_1 \\ X_2 f_2 \end{pmatrix} = M \times X$$

where X is the ordered set of all monomials appearing in $X_i f_i$ for $i = 0, 1, 2$. Note in order for M to qualify as a resultant matrix, $|X_0| \geq \mu(\mathcal{A}_1, \mathcal{A}_2)$; similar conditions can be written for X_1 and X_2 .

If it can be shown that the matrix M above is square and non-singular, then it is the resultant matrix since the determinant of M is a multiple of the resultant. Moreover, if $|X_i| = \mu_i$, then M is exact, in the sense that its determinant is exactly the resultant of $\mathcal{F} = \{f_0, f_1, f_2\}$.

3 Dixon Resultant Matrix

In this section, we briefly review the generalized Dixon formulation, first introduced by Dixon [Dix08], and generalized by Kapur, Saxena and Yang [KSY94, KS96]. We will consider the bivariate case only.

Define the *Dixon polynomial* to be

$$\theta_{x,y}(f_0, f_1, f_2) = \frac{1}{(\bar{x} - x)(\bar{y} - y)} \begin{vmatrix} f_0(x, y) & f_1(x, y) & f_2(x, y) \\ f_0(\bar{x}, y) & f_1(\bar{x}, y) & f_2(\bar{x}, y) \\ f_0(\bar{x}, \bar{y}) & f_1(\bar{x}, \bar{y}) & f_2(\bar{x}, \bar{y}) \end{vmatrix},$$

where \bar{x} and \bar{y} are new variables. Let \bar{X} be an ordered set of all monomials appearing in $\theta(f_0, f_1, f_2)$ in terms of variables \bar{x}, \bar{y} , and X be the set of all monomial in terms of variables x and y . Then

$$\theta_{x,y}(f_0, f_1, f_2) = \bar{X} \Theta_{x,y} X,$$

where $\Theta_{x,y}$ is called the *Dixon matrix*. Note that $\Theta_{x,y} = \Theta_{y,x}^T$, where the order of variables x, y is reversed; we will thus drop variable subscripts since it suffices to consider any variable order.

¹The sum $\mathcal{A}_1 + \mathcal{A}_2$ is the Minkowski sum of polytopes $\mathcal{A}_1, \mathcal{A}_2$, where $p \in \mathcal{A}_1 + \mathcal{A}_2$ if $p = q + r$ for $q \in \mathcal{A}_1$ and $r \in \mathcal{A}_2$ where $+$ is the regular vector addition, see [CLO98] and others.

If $\mathcal{F} = \{f_0, f_1, f_2\}$ has a common zero, it is also a zero of $\theta(f_0, f_1, f_2)$ for any value of new variables \bar{x} and \bar{y} . Thus,

$$\Theta \times X = 0, \tag{1}$$

whenever x, y are replaced by a common zero of f_0, f_1, f_2 .

For polynomials $\{f_0, f_1, f_2\}$ to have a common zero, the equation (1) must be satisfied. If Θ is square and nonsingular, then its determinant must vanish, implying that under certain conditions, Θ is a resultant matrix. Even though this matrix is quite different from matrices constructed using the Sylvester dialytic method, there is direct connection between the two which will be discussed later (see also [CK00b]).

We are interested in identifying conditions when the resultant matrix Θ is **exact**, i.e., its determinant is exactly (up to a constant factor) the resultant. Also, when it is not, we are interested in predicting the extraneous factor in the determinant of Θ (at the very least the degree of the extraneous factor). We are thus interested in analyzing the size and structure of the monomial set X ; its size tells the number of columns in Θ and hence, whether or not, Θ is exact.

4 Support Structure of Dixon Polynomial

As $\mathcal{A} = \langle \mathcal{A}_0, \mathcal{A}_1, \mathcal{A}_2 \rangle$, by $\sigma \in \mathcal{A}$, we mean the triple $\langle \alpha, \beta, \gamma \rangle$ such that $\alpha \in \mathcal{A}_0$, $\beta \in \mathcal{A}_1$ and $\gamma \in \mathcal{A}_2$.

The Dixon polynomial above can be expressed using the Cauchy-Binet formula as a sum of Dixon matrices of 3 point set supports as shown below.

$$\theta(f_0, f_1, f_2) = \sum_{\sigma \in \mathcal{A}} \sigma(\mathbf{c}) \sigma(\mathbf{x}), \tag{2}$$

where

$$\sigma(\mathbf{c}) = \begin{vmatrix} a_\alpha & a_\beta & a_\gamma \\ b_\alpha & b_\beta & b_\gamma \\ c_\alpha & c_\beta & c_\gamma \end{vmatrix} \quad \text{and} \quad \sigma(\mathbf{x}) = \frac{1}{(\bar{x} - x)(\bar{y} - y)} \begin{vmatrix} x^{\alpha_x} y^{\alpha_y} & \bar{x}^{\alpha_x} y^{\alpha_y} & \bar{x}^{\alpha_x} \bar{y}^{\alpha_y} \\ x^{\beta_x} y^{\beta_y} & \bar{x}^{\beta_x} y^{\beta_y} & \bar{x}^{\beta_x} \bar{y}^{\beta_y} \\ x^{\gamma_x} y^{\gamma_y} & \bar{x}^{\gamma_x} y^{\gamma_y} & \bar{x}^{\gamma_x} \bar{y}^{\gamma_y} \end{vmatrix}.$$

In a generic case, where $\sigma(\mathbf{c}) \neq 0$ the support of the Dixon polynomial is the union of supports of $\sigma(\mathbf{x})$, where $\sigma(\mathbf{x})$ is the Dixon polynomial of the monomials corresponding to $\sigma = \langle \alpha, \beta, \gamma \rangle$.

As seen from the above formula, in the generic case, the support of the Dixon polynomial as well as the size of the Dixon matrix is completely determined by the support of the polynomial system \mathcal{F} ; we thus write the support of the Dixon polynomial as

$$\Delta_{\mathcal{A}} = S_{\mathbf{x}}(\theta(f_0, f_1, f_2)) \quad \text{where} \quad \mathcal{A}_0 = S_{\mathbf{x}}(f_0), \mathcal{A}_1 = S_{\mathbf{x}}(f_1), \mathcal{A}_2 = S_{\mathbf{x}}(f_2).$$

We will also denote by $\theta_{\mathcal{A}}$, the Dixon polynomial of the generic polynomial system with support \mathcal{A} .

Proposition 4.1 $\Delta_{\mathcal{A}} = \bigcup_{\sigma \in \mathcal{A}} \Delta_{\sigma}$.

If $|\mathcal{A}_i| = 1$ for $i = \{0, 1, 2\}$, we can give the precise description of $\Delta_{\mathcal{A}}$: it is union of two disjoint adjacent rectangles as discussed below.

Definition 4.1 A box support \mathcal{B}_u^v , where $u, v \in \mathbb{N}^2$ is a dense rectangular support located at u , and is defined as

$$\mathcal{B}_u^v = \{ (i, j) \mid u_x \leq i < v_x \quad \text{and} \quad u_y \leq j < v_y \}.$$

Given a support $\mathcal{A} = \langle \mathcal{A}_0, \mathcal{A}_1, \mathcal{A}_2 \rangle$, let $\mathcal{B}_{\mathcal{A}}$ stand for the smallest box support containing all \mathcal{A}_i 's.

Proposition 4.2 *Let $\sigma = \{\alpha, \beta, \gamma\}$ be a 3-point support such that $\alpha_x \leq \beta_x \leq \gamma_x$ (w.l.o.g.); consider a generic polynomial support with the support σ . Then*

$$\Delta_\sigma = \Delta_L \cup \Delta_H \quad \text{and} \quad \Delta_L \cap \Delta_H = \emptyset \quad \text{where} \quad \Delta_L = \mathcal{B}_s^t \quad \text{and} \quad \Delta_H = \mathcal{B}_p^q,$$

$L = \{\alpha, \beta, (\beta_x, \gamma_y)\}$, $H = \{(\beta_x, \alpha_y), \beta, \gamma\}$, and

$$\begin{aligned} s_x &= \alpha_x & p_x &= \beta_x \\ t_x &= \beta_x & q_x &= \gamma_x \\ s_y &= \alpha_y + \min(\beta_y, \gamma_y) & p_y &= \beta_y + \min(\alpha_y, \gamma_y) \\ t_y &= \alpha_y + \max(\beta_y, \gamma_y) & q_y &= \beta_y + \max(\alpha_y, \gamma_y). \end{aligned}$$

Proof: The Dixon polynomial θ_σ of σ has the same monomials even when $\bar{x} = 1$ and $\bar{y} = 1$. Substituting $\bar{x} = 1$ and $\bar{y} = 1$ does not eliminate any monomials in x, y due to cancellation. So,

$$S_{\mathbf{x}}(\theta_\sigma) = S_{\mathbf{x}}\left(\theta_\sigma \Big|_{\substack{\bar{x}=1 \\ \bar{y}=1}}\right).$$

Since

$$\begin{aligned} \begin{vmatrix} x^{\alpha_x} y^{\alpha_y} & y^{\alpha_y} & 1 \\ x^{\beta_x} y^{\beta_y} & y^{\beta_y} & 1 \\ x^{\gamma_x} y^{\gamma_y} & y^{\gamma_y} & 1 \end{vmatrix} &= \left(\begin{vmatrix} x^{\alpha_x} y^{\alpha_y} & y^{\alpha_y} & 1 \\ x^{\beta_x} y^{\beta_y} & y^{\beta_y} & 1 \\ x^{\beta_x} y^{\gamma_y} & y^{\gamma_y} & 1 \end{vmatrix} + \begin{vmatrix} x^{\beta_x} y^{\alpha_y} & y^{\alpha_y} & 1 \\ x^{\beta_x} y^{\beta_y} & y^{\beta_y} & 1 \\ x^{\gamma_x} y^{\gamma_y} & y^{\gamma_y} & 1 \end{vmatrix} \right) \\ &= (x^{\alpha_x} - x^{\beta_x})(y^{\alpha_y + \beta_y} - y^{\alpha_y + \gamma_y}) + (x^{\beta_x} - x^{\gamma_x})(y^{\beta_y + \gamma_y} - y^{\alpha_y + \gamma_y}), \end{aligned}$$

$$S_{\mathbf{x}}(\theta_\sigma) = S_{\mathbf{x}}\left(\frac{(x^{\alpha_x} - x^{\beta_x}) y^{\alpha_y} (y^{\beta_y} - y^{\gamma_y})}{1-x} + \frac{(x^{\beta_x} - x^{\gamma_x}) y^{\gamma_y} (y^{\beta_y} - y^{\alpha_y})}{1-x}\right).$$

The monomials coming from the two fractions are disjoint. Further, the support of each fraction is \mathcal{B}_s^t and \mathcal{B}_p^q , respectively. \square

4.1 Support of Dixon Polynomial: A Generic System with Box Support

An unmixed polynomial system such that $\mathcal{A}_i = \mathcal{B}_u^v$ for some $u, v \in \mathbb{N}$ and $u = (0, 0)$, is called a **bi-degree** system. We allow u to be arbitrary, as one can shift the entire support to the origin, compute the Dixon polynomial of the new *shifted* polynomial system, and then multiply the result with the appropriate monomial.

Dixon in [Dix08] generalized the Bezout method for dense bi-degree polynomial systems, and established that matrices constructed using that method are exact, that their determinants are the resultants of the polynomial systems. The support structure of the Dixon polynomial has been known, and is generalized to the n -degree systems in [KS96] and [Sax97]. Here we give the precise description of a bi-degree system.

Proposition 4.3 *The support of the Dixon polynomial of a bi-degree system is a rectangular region*

$$\Delta_{\mathcal{B}_u^v} = \mathcal{B}_s^t \quad \text{where} \quad t = (v_x - 1, 2v_y - 1) \quad \text{and} \quad s = (u_x, 2u_y).$$

Proof: $\Delta_{\mathcal{B}_u^v} \subseteq \mathcal{B}_u^t$ as the exponents of monomials of $\theta_{\mathcal{B}_u^v}$ cannot be outside \mathcal{B}_u^t . The expansion of the Dixon polynomial $\theta_{\mathcal{B}_u^v}$ has two simplexes among others which include all support points in \mathcal{B}_u^t . Let $\sigma_1 = \langle u, v, (v_x, u_y) \rangle$ and $\sigma_2 = \langle u, v, (u_x, v_y) \rangle$. Using Proposition 4.2, it can be seen that these simplexes result in the entire \mathcal{B}_u^t . \square

The size of $\Delta_{\mathcal{B}_u^v}$ of the box support \mathcal{B}_u^v is $2(v_x - u_x)(v_y - u_y)$, which is precisely the mixed volume of any two polynomials with \mathcal{B}_u^v as support; hence, the Dixon matrix is exact for such a polynomial system.

Another important point about box supports is that points “inside” the box support do not play any role in determining the support of the Dixon polynomial (which can be seen, from the proof of the above proposition). Later we will give a precise description of points which do not influence the support of the Dixon polynomial. Identifying such “interior” points and not using them in computations can reduce the cost of algorithms based on this method.

4.2 Support Complement

Given an arbitrary unmixed support \mathcal{A} , we can analyze how different it is from a bi-degree system having $\mathcal{B}_{\mathcal{A}}$ as its support. We will define complement of \mathcal{A} w.r.t. $\mathcal{B}_{\mathcal{A}}$ in terms of simplexes making up \mathcal{A} .

Definition 4.2 *Given an unmixed polynomial system support with \mathcal{A} the complement of \mathcal{A} w.r.t. $\mathcal{B}_{\mathcal{A}}$ is defined as the set $\mathcal{C}_{\mathcal{A}}$ expressed as:*

$$\mathcal{C}_{\mathcal{A}} = \mathcal{C}_{00}^{\mathcal{A}} \cup \mathcal{C}_{01}^{\mathcal{A}} \cup \mathcal{C}_{10}^{\mathcal{A}} \cup \mathcal{C}_{11}^{\mathcal{A}},$$

where each $\mathcal{C}_{i,j}^{\mathcal{A}}$, $i, j \in \{0, 1\}$, is called a corner complement-support of \mathcal{A} , and each $\mathcal{C}_{i,j}^{\mathcal{A}}$ satisfies the property that if $c \in \mathcal{C}_{i,j}^{\mathcal{A}}$, then there does not exist $p \in \mathcal{A}$ such that

$$\begin{aligned} p_x \leq c_x \text{ if } i = 0 & \quad \text{and} \quad p_x \geq c_x \text{ if } i = 1, \\ p_y \leq c_y \text{ if } j = 0 & \quad \text{and} \quad p_y \geq c_y \text{ if } j = 1. \end{aligned}$$

The complement of a support can also be defined as the intersection of simplexes making up the support, which with some technicalities, can be extended to mixed supports as well. The next proposition establishes the equivalence of the two definitions for the unmixed case.

Proposition 4.4 *The support complement of \mathcal{A} , the set $\mathcal{C}_{\mathcal{A}} = \mathcal{C}_{00}^{\mathcal{A}} \cup \mathcal{C}_{01}^{\mathcal{A}} \cup \mathcal{C}_{10}^{\mathcal{A}} \cup \mathcal{C}_{11}^{\mathcal{A}}$ can be expressed as intersection, where*

$$\mathcal{C}_{i,j}^{\mathcal{A}} = \bigcap_{\sigma \in \mathcal{A}} \mathcal{C}_{i,j}^{\sigma}.$$

Proof: Any point c which is in the intersection of corner complement supports of σ , satisfies the definition for being in corner complement of \mathcal{A} , since for all $\sigma \in \mathcal{A}$, there was no point p preventing c from being in complement support, hence there was no such point in \mathcal{A} . \square

Figure 1 shows the support complement for an unmixed support \mathcal{A} , where the four corners are outlined. As the reader would notice, $\mathcal{C}_{10}^{\mathcal{A}}$ and $\mathcal{C}_{01}^{\mathcal{A}}$ overlap.

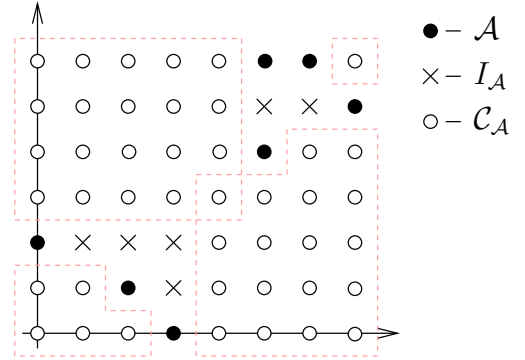

Figure 1: Complement Supports

Definition 4.3 *Given an arbitrary box support \mathcal{B}_u^v and a support complement $\mathcal{C}_{\mathcal{A}} = \mathcal{C}_{00}^{\mathcal{A}} \cup \mathcal{C}_{01}^{\mathcal{A}} \cup \mathcal{C}_{10}^{\mathcal{A}} \cup \mathcal{C}_{11}^{\mathcal{A}}$, of some support \mathcal{A} , let the support $\mathcal{B}_u^v / \langle \mathcal{C}_{00}^{\mathcal{A}}, \mathcal{C}_{01}^{\mathcal{A}}, \mathcal{C}_{10}^{\mathcal{A}}, \mathcal{C}_{11}^{\mathcal{A}} \rangle$ stand for the box support with four corner complement-supports $\langle \mathcal{C}_{00}^{\mathcal{A}}, \mathcal{C}_{01}^{\mathcal{A}}, \mathcal{C}_{10}^{\mathcal{A}}, \mathcal{C}_{11}^{\mathcal{A}} \rangle$ removed from it. More precisely, the points $(0, 0)$ of $\mathcal{C}_{00}^{\mathcal{A}}$, $(0, \max_y)$ of $\mathcal{C}_{01}^{\mathcal{A}}$, $(\max_x, 0)$ of $\mathcal{C}_{10}^{\mathcal{A}}$, and (\max_x, \max_y) of $\mathcal{C}_{11}^{\mathcal{A}}$ are located, respectively, at (u_x, u_y) , (u_x, v_y) , (v_x, u_y) , (v_x, v_y) of \mathcal{B}_u^v .*

With this notation we can now establish a connection between the polynomial support \mathcal{A} and the support $\Delta_{\mathcal{A}}$ of its Dixon polynomial.

4.3 Support of Dixon Polynomial: General Case

An interesting property of the support of the Dixon polynomial is that it admits a concise geometric description, given that it is a union of the supports of the Dixon polynomial of polynomial systems with smaller support sets. The following theorem gives the support of the Dixon polynomial of a bivariate polynomial system in terms of how different the support of the polynomial system is from the bi-degree support. It also enables computing the support of the Dixon polynomial without expanding all determinants in the formula for the Dixon polynomial. Figure 2, shows the support of the Dixon polynomial for the unmixed polynomial system shown in Figure 1.

Theorem 4.1 For any given unmixed support \mathcal{A} , with $\mathcal{C}_{\mathcal{A}} = \mathcal{C}_{00}^{\mathcal{A}} \cup \mathcal{C}_{01}^{\mathcal{A}} \cup \mathcal{C}_{10}^{\mathcal{A}} \cup \mathcal{C}_{11}^{\mathcal{A}}$ as a complement support,

$$\Delta_{\mathcal{A}} = \Delta_{\mathcal{B}_{\mathcal{A}}} / \langle \mathcal{C}_{00}^{\mathcal{A}}, \mathcal{C}_{01}^{\mathcal{A}}, \mathcal{C}_{10}^{\mathcal{A}}, \mathcal{C}_{11}^{\mathcal{A}} \rangle.$$

Proof: Let $D_{\mathcal{A}} = \Delta_{\mathcal{B}_{\mathcal{A}}} / \langle \mathcal{C}_{00}^{\mathcal{A}}, \mathcal{C}_{01}^{\mathcal{A}}, \mathcal{C}_{10}^{\mathcal{A}}, \mathcal{C}_{11}^{\mathcal{A}} \rangle$. First we will prove for the case when $\mathcal{A} = \sigma$. Then, since $D_{\mathcal{A}} = \bigcup_{\sigma \in \mathcal{A}} D_{\sigma}$, and $\Delta_{\mathcal{A}}$ satisfies similar properties, the statement of the theorem will be shown.

Let $\sigma = \langle \alpha, \beta, \gamma \rangle$ be a simplex; w.l.o.g., assume $\alpha_x \leq \beta_x \leq \gamma_x$. The proof is similar to that of proposition 4.2. Let $\alpha' = (\beta_x, \alpha_y)$ and $\gamma' = (\beta_x, \gamma_y)$, where $\sigma_1 = \langle \alpha, \beta, \gamma' \rangle$ and $\sigma_2 = \langle \alpha', \beta, \gamma \rangle$. Since $\Delta_{\mathcal{B}_{\sigma}} = \Delta_{\mathcal{B}_{\sigma_1}} \cup \Delta_{\mathcal{B}_{\sigma_2}}$ and $\Delta_{\mathcal{B}_{\sigma_1}} \cap \Delta_{\mathcal{B}_{\sigma_2}} = \emptyset$. The support complements of σ_1 and σ_2 are disjoint as well, and their union is the support complement of σ .

$$\mathcal{C}_{ij}^{\sigma} = \mathcal{C}_{ij}^{\sigma_1} \cup \mathcal{C}_{ij}^{\sigma_2} \quad \text{for all } i, j \in \{0, 1\}.$$

Therefore

$$D_{\sigma} = \Delta_{\mathcal{B}_{\sigma}} / \langle \mathcal{C}_{00}^{\sigma}, \mathcal{C}_{01}^{\sigma}, \mathcal{C}_{10}^{\sigma}, \mathcal{C}_{11}^{\sigma} \rangle = (\Delta_{\mathcal{B}_{\sigma_1}} / \langle \mathcal{C}_{00}^{\sigma_1}, \mathcal{C}_{01}^{\sigma_1}, \mathcal{C}_{10}^{\sigma_1}, \mathcal{C}_{11}^{\sigma_1} \rangle) \cup (\Delta_{\mathcal{B}_{\sigma_2}} / \langle \mathcal{C}_{00}^{\sigma_2}, \mathcal{C}_{01}^{\sigma_2}, \mathcal{C}_{10}^{\sigma_2}, \mathcal{C}_{11}^{\sigma_2} \rangle) = D_{\sigma_1} \cup D_{\sigma_2}.$$

We thus have:

$$D_{\sigma} = D_{\sigma_1} \cup D_{\sigma_2} \quad \text{and} \quad D_{\sigma_1} \cap D_{\sigma_2} = \emptyset.$$

Sets D_{σ_1} and D_{σ_2} are rectangles:

$$\begin{aligned} D_{\sigma_1} &= \{ (p_x, p_y) \mid \alpha_x \leq p_x < \beta_x \quad \text{and} \quad \min(\beta_y, \gamma_y) \leq p_y - \alpha_y < \max(\beta_y, \gamma_y) - 1 \} \\ D_{\sigma_2} &= \{ (p_x, p_y) \mid \beta_x \leq p_x < \gamma_x \quad \text{and} \quad \min(\alpha_y, \beta_y) \leq p_y - \gamma_y < \max(\alpha_y, \beta_y) - 1 \}. \end{aligned} \quad \text{and}$$

From Proposition 4.2, this is exactly the two support sets whose union is Δ_{σ} .

Now to the statement of the theorem. As in the case of $\Delta_{\mathcal{A}}$, $D_{\mathcal{A}}$ is the union of simplexes, that is

$$D_{\mathcal{A}} = \bigcup_{\sigma \in \mathcal{A}} D_{\sigma}$$

- Case $D_{\sigma} \subseteq D_{\mathcal{A}}$. Let $p \in D_{\sigma}$ where $\sigma = \{\alpha, \beta, \gamma\} \in \mathcal{A}$. Clearly $p \in \Delta_{\mathcal{B}_{\mathcal{A}}}$, since $\Delta_{\mathcal{B}_{\sigma}} \subseteq \Delta_{\mathcal{B}_{\mathcal{A}}}$, we need to show that $p \notin \{\mathcal{C}_{00}^{\mathcal{A}}, \mathcal{C}_{01}^{\mathcal{A}}, \mathcal{C}_{10}^{\mathcal{A}}, \mathcal{C}_{11}^{\mathcal{A}}\}$. But this is clear since $p \notin \{\mathcal{C}_{00}^{\sigma}, \mathcal{C}_{01}^{\sigma}, \mathcal{C}_{10}^{\sigma}, \mathcal{C}_{11}^{\sigma}\}$, and $\mathcal{C}_{i,j}^{\mathcal{A}} \subseteq \mathcal{C}_{i,j}^{\sigma}$ in $\mathcal{B}_{\mathcal{A}}$.
- Case $D_{\mathcal{A}} \subseteq \bigcup D_{\sigma}$. Let $p \in D_{\mathcal{A}}$ we need to find $\sigma = \{\alpha, \beta, \gamma\} \in \mathcal{A}$ such that $p \in D_{\sigma}$. Since $p \in \Delta_{\mathcal{A}}$, there exist $\alpha, \beta, \gamma, \delta \in \mathcal{A}$ such that

$$\begin{aligned} \alpha_x &\leq p_x < \beta_x \\ \gamma_y &\leq p_y < \gamma_y + \delta_y \end{aligned} \quad \text{and} \quad (3)$$

moreover $p \in D_{\{\alpha, \beta, \gamma, \delta\}}$. We need to show that 3 points will suffice. This should be apparent that to satisfy equations of (3) only three points are necessary as depending on configuration α can be replaced by γ or δ , or β can be replaced by γ or δ \square .

The above proof also suggest that for any mixed support \mathcal{A} , there is an unmixed polynomial system support \mathcal{A}' such that

$$\Delta_{\mathcal{A}} = \Delta_{\mathcal{A}'}$$

This is so because the above proof as well as the proof of Propositions 4.1 and 4.2 do not depend upon the polynomial system being unmixed. This important property will enable determining when the Dixon formulation will compute the resultant exactly even for mixed polynomial systems. It will also give insight into the upper bound on the degree of the extraneous factor when the resultant cannot be computed exactly using the Dixon formulation.²

²These results and observations will be discussed in a forthcoming paper.

$\Delta_{\mathcal{A}}$ is dependent on the variable order used in $\theta_{\mathcal{A}}$, but the size of $\Delta_{\mathcal{A}}$ is the same for any variable order if \mathcal{A} is unmixed (by Theorem 4.1). Hence, the Dixon matrix is square for unmixed polynomial systems, but it need not be square for mixed polynomial systems.

4.4 Support Interior

In this subsection, the role of points in the convex hull of a given support \mathcal{A} vis a vis their contribution to the resultant and extraneous factors generated by the Dixon formulation are investigated. Points in the convex hull of a support can be classified into two broad categories: (i) terms whose inclusion into the polynomial system does not change the resultant (or the projection operator), and (ii) terms whose inclusion into the polynomial system changes the projection operator and can result in more extraneous factors. First, the concept of an *interior point* relative to a support is introduced. Intuitively, an interior point is a point whose presence in the support of a polynomial in a given polynomial system does not change the support of its Dixon polynomial.

A point p can be *interior* w.r.t. support \mathcal{A} , but be not interior w.r.t all $\sigma \in \mathcal{A}$ as shown in Figure 3. This notion is non-trivial with respect to computation of the Dixon polynomial and hence, the Dixon matrix.

Definition 4.4 A point p is called **support-interior** w.r.t unmixed support \mathcal{A} if and only if $\exists \{\alpha, \beta, \gamma, \delta\} \in \mathcal{A}_i$ for some i , such that

$$\begin{aligned} \alpha_x \leq p_x \leq \beta_x & \quad \text{and} \quad \gamma_x \leq p_x \leq \delta_x \\ \alpha_y \leq p_y \leq \beta_y & \quad \gamma_y \geq p_y \geq \delta_y. \end{aligned}$$

Definition 4.4 is geometric that allows to verify a given point for being in support interior with respect to \mathcal{A} .

Given \mathcal{A} , let $I_{\mathcal{A}}$ stand for the subset of \mathcal{A} consisting of all support-interior points of \mathcal{A} and $\overline{\mathcal{A}} = \mathcal{A} \cup I_{\mathcal{A}}$; $I_{\mathcal{A}}$ is called the *support-interior* of \mathcal{A} . For example, all points of the box support \mathcal{B}_u^v are support-interior with the exception of the four corner points.

It is easy to see that a support-interior point is in the convex hull of \mathcal{A} , but the converse is not necessarily the case. For example, the convex hull of support $\{(0, 0), (0, 2), (2, 0)\}$ contains the point $(1, 1)$, but it is not a support-interior point. Support-interior of \mathcal{A} is also not the same as the convex hull interior, but is a subset of the convex hull interior as shown below.

Proposition 4.5 Given a support \mathcal{A} , its support interior $I_{\mathcal{A}}$ is contained in the Newton polytope of \mathcal{A} , i.e.

$$I_{\mathcal{A}} \subset \text{cHull}(\mathcal{A}) \cap \mathbb{N}^2.$$

Proof: Consider any support-interior point $p = (p_x, p_y)$ in \mathcal{A} . By definition, there are points a, b, c, d satisfying the above stated condition on the coordinates of p, a, b, c, d . Since (i) the intersection points of line $x = p_x$ with lines ad and bc are in the convex hull and (ii) p lies in between these intersection points, p is in the convex hull. \square .

In the construction of $\Delta_{\mathcal{A}}$, it does not matter whether \mathcal{A} is used or $\overline{\mathcal{A}}$ is used. In other words, extending \mathcal{A} with its support-interior points will not change $\Delta_{\mathcal{A}}$.

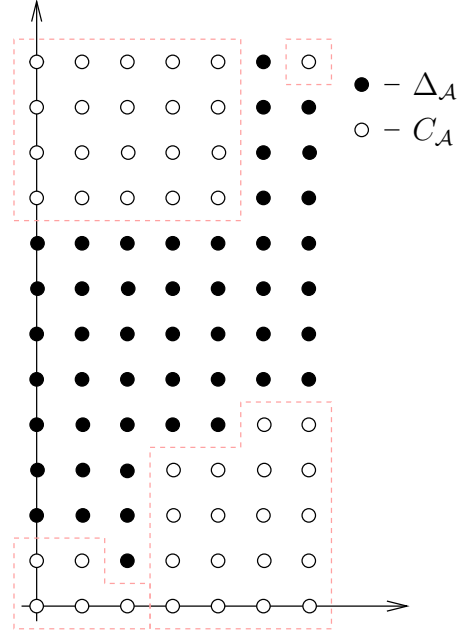

Figure 2: $\Delta_{\mathcal{A}}$ where \mathcal{A} is from figure 1

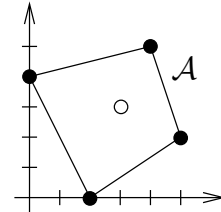

Figure 3: Support interior point w.r.t. \mathcal{A}

Theorem 4.2 Given a support \mathcal{A} ,

$$\Delta_{\mathcal{A}} = \Delta_{\overline{\mathcal{A}}}$$

Proof: Clearly, presence of support interior point does not change $\mathcal{B}_{\mathcal{A}}$, nor any of $\mathcal{C}_{i,j}^{\mathcal{A}}$, therefore has no effect on $\Delta_{\mathcal{A}}$, the Dixon polynomial support.

On the other hand if point is not support interior, then it belongs to one of $\mathcal{C}_{i,j}^{\mathcal{A}}$, and hence changes $\Delta_{\mathcal{A}}$. \square .

5 Dixon Matrix Size: Exact Cases vs Extraneous Factors

In this section, we relate the size of the Dixon matrix associated with a given polynomial system, which is determined by the size of the support of its Dixon polynomial, to the BKK bound on the number of its toric roots, which is determined by the mixed volume of the Newton polytopes of its supports. We identify necessary and sufficient conditions on the support of the polynomial system under which the Dixon matrix is exact in the sense that its size is precisely the BKK bound. When these conditions on the support are not satisfied, we give an estimate on the degree of the extraneous factor in the projection operator extracted from the Dixon matrix by relating its size to the BKK bound.

Theorem 5.1 The size of the Dixon matrix of an unmixed polynomial system $\mathcal{F} = \{f_0, f_1, f_2\}$ with support \mathcal{A} is

$$|\Delta_{\mathcal{A}}| = |\Delta_{\mathcal{B}_{\mathcal{A}}}| - |\mathcal{C}_{00}^{\mathcal{A}}| - |\mathcal{C}_{01}^{\mathcal{A}}| - |\mathcal{C}_{10}^{\mathcal{A}}| - |\mathcal{C}_{11}^{\mathcal{A}}|.$$

Proof: Note that $\mathcal{C}_{i,j}^{\mathcal{A}}$ does not overlap w.r.t. $\Delta_{\mathcal{B}_{\mathcal{A}}}$; $\mathcal{C}_{00}^{\mathcal{A}}$ and $\mathcal{C}_{11}^{\mathcal{A}}$ do not intersect $\mathcal{C}_{10}^{\mathcal{A}}$ or $\mathcal{C}_{01}^{\mathcal{A}}$. Even if $\mathcal{C}_{00}^{\mathcal{A}}$ intersects $\mathcal{C}_{11}^{\mathcal{A}}$ w.r.t. $\mathcal{B}_{\mathcal{A}}$, then they cannot intersect w.r.t. $\Delta_{\mathcal{B}_{\mathcal{A}}}$ as $\Delta_{\mathcal{B}_{\mathcal{A}}}$ is almost twice the size of $\mathcal{B}_{\mathcal{A}}$, and $\mathcal{C}_{00}^{\mathcal{A}}$ is obviously smaller than $\mathcal{B}_{\mathcal{A}}$. This is true for $\mathcal{C}_{01}^{\mathcal{A}}$ and $\mathcal{C}_{10}^{\mathcal{A}}$ as well. Then the theorem follows directly from theorem 4.1 and the definition of $\Delta_{\mathcal{A}}$. \square .

How does the size of the Dixon matrix compare with the BKK bound of \mathcal{F} ? For the unmixed case, if the size of the Dixon matrix equals the BKK bound of any two polynomials in \mathcal{F} , then the matrix is exact, i.e., its determinant is exactly the toric resultant. To see the relationship between the BKK bound which is defined in terms of Newton polytopes, and the size of the Dixon matrix, we can characterize how different the convex hull of the support \mathcal{A} is from the box support using *corners*. Let

$$\mathcal{Q} = \text{Conv}_{\text{hull}}(\mathcal{B}_{\mathcal{A}}) - \text{Conv}_{\text{hull}}(\mathcal{A}),$$

which can be split into four disjoint, not necessarily convex, polyhedral sets:

$$\mathcal{Q} = \mathcal{Q}_{00}^{\mathcal{A}} \cup \mathcal{Q}_{01}^{\mathcal{A}} \cup \mathcal{Q}_{10}^{\mathcal{A}} \cup \mathcal{Q}_{11}^{\mathcal{A}}.$$

Figure 4 shows the Newton polytope complement for the earlier example shown in figure 2.

For an unmixed polynomial system, the BKK bound, which is the mixed volume of any two polynomials with the support \mathcal{A} , is

$$\mu(\mathcal{A}_0, \mathcal{A}_1) = 2\text{Vol}(\mathcal{A}_0) = 2\text{Vol}(\mathcal{B}_{\mathcal{A}}) - 2\text{Vol}(\text{Conv}_{\text{hull}}(\mathcal{B}_{\mathcal{A}}) - \text{Conv}_{\text{hull}}(\mathcal{A}_0)) = 2\text{Vol}(\mathcal{B}_{\mathcal{A}}) - 2\text{Vol}(\mathcal{Q}).$$

Since $\mathcal{C}_{i,j}^{\mathcal{A}}$ are disjoint in $\Delta_{\mathcal{B}_{\mathcal{A}}}$, the Dixon matrix is exact if and only if

$$2\text{Vol}(\mathcal{Q}) = 2\text{Vol}(\mathcal{Q}_{00}^{\mathcal{A}}) + 2\text{Vol}(\mathcal{Q}_{01}^{\mathcal{A}}) + 2\text{Vol}(\mathcal{Q}_{10}^{\mathcal{A}}) + 2\text{Vol}(\mathcal{Q}_{11}^{\mathcal{A}}) = |\mathcal{C}_{00}^{\mathcal{A}}| + |\mathcal{C}_{01}^{\mathcal{A}}| + |\mathcal{C}_{10}^{\mathcal{A}}| + |\mathcal{C}_{11}^{\mathcal{A}}|.$$

Proposition 5.1 (i) $|\mathcal{C}_{i,j}^{\mathcal{A}}| \leq 2\text{Vol}(\mathcal{Q}_{i,j}^{\mathcal{A}})$, and (ii) $|\mathcal{C}_{i,j}^{\mathcal{A}}| = 2\text{Vol}(\mathcal{Q}_{i,j}^{\mathcal{A}})$ if and only if each $\mathcal{C}_{i,j}^{\mathcal{A}}$ is a rectangle.

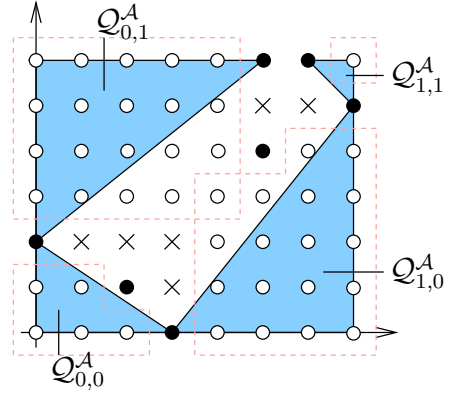

Figure 4: Newton polytope Complement

Proof: If $\mathcal{C}_{i,j}^A$ is a rectangle, then $\mathcal{Q}_{i,j}^A$ is a triangle, whose area is half of the area of $\mathcal{C}_{i,j}^A$. But the number of lattice points in this rectangle belonging to $\mathcal{C}_{i,j}^A$ equals to twice the volume of $\mathcal{Q}_{i,j}^A$.

Assume some $\mathcal{C}_{i,j}^A$ is not a rectangle. Then, it can be broken up into vertical rectangles R_1, \dots, R_n , such that

$$\mathcal{C}_{i,j}^A = \bigcup_{k=1}^n R_k \quad \text{and} \quad |\mathcal{C}_{i,j}^A| = \sum_{k=1}^n |R_k|.$$

Note that $|R_i| \leq 2\text{Vol}(\text{Conv}(R_i) - \text{Conv}(\mathcal{A}))$; further $|R_i| = 2\text{Vol}(\text{Conv}(R_i) - \text{Conv}(\mathcal{A}))$ only when \mathcal{A} intersects R_i diagonally. Since \mathcal{A} cannot intersect every R_i diagonally, without making $\mathcal{C}_{i,j}^A$ a rectangle, the number of points in $\mathcal{C}_{i,j}^A$ is less than twice the volume of the given corner. \square .

We have the main result of the paper:

Theorem 5.2 *The size of the Dixon matrix of an unmixed generic polynomial system $\mathcal{F} = \{f_0, f_1, f_2\}$ with support \mathcal{A} is*

$$|\Delta_{\mathcal{A}}| = \mu(\mathcal{A}, \mathcal{A}) + \sum_{i,j \in \{0,1\}} (2\text{Vol}(\mathcal{Q}_{i,j}^A) - |\mathcal{C}_{i,j}^A|) = \mu(\mathcal{A}, \mathcal{A}) + D_e.$$

D_e is an upper bound on the degree of the extraneous factor in the projection operator expressed in the coefficients of f_0 , f_1 and f_2 and extracted from the Dixon matrix.

In [CK00a], a method based on partitioning the support of an unmixed polynomial system is given for estimating the degree of the extraneous factor in the projection operator extracted from the associated Dixon matrix. The above theorem generalizes that result; instead of breaking up the support into smaller supports, it gives a better insight into the existence of extraneous factors. Further, the estimate on the degree of an extraneous factor can be calculated efficiently using the above relation.

From the above theorem, there is a nice characterization of all bivariate unmixed polynomial systems for which the Dixon method computes the resultant exactly.

Theorem 5.3 *Given an unmixed generic polynomials system with support \mathcal{A} such that $\mathcal{C}_{\mathcal{A}} = \{\mathcal{C}_{00}^A, \mathcal{C}_{01}^A, \mathcal{C}_{10}^A, \mathcal{C}_{11}^A\}$, the Dixon method computes its resultant exactly if and only if each $\mathcal{C}_{i,j}^A$ is a rectangle.*

Another implication of the above theorems together with theorem 4.2 is that inclusion of terms corresponding to support-interior points in a polynomial system do not change the support of the Dixon polynomial and hence, the size of Dixon matrix and the degree of projection operator. However, inclusion of terms corresponding to points in the convex hull of the support but which are not support-interior can contribute to the extraneous factors in the projection operator. But that is not the only source of extraneous factors in a projection operator. Even polynomial systems whose support does not have any points inside its convex hull can have extraneous factors in the projection operator computed by the Dixon method; consider example 8, for instance, in section 8 where examples are discussed.

5.1 Estimating the Degree of the Extraneous Factor

If the points in \mathcal{A} are assumed to be sorted, there is a linear algorithm to test whether or not a support is exact. We need to compute $|\mathcal{C}_{00}^A| + |\mathcal{C}_{01}^A| + |\mathcal{C}_{10}^A| + |\mathcal{C}_{11}^A|$ as well the volume of \mathcal{A} . To compute $|\mathcal{C}_{0,0}^A|$, for instance, consider the following algorithm.

1. Sort points of \mathcal{A} into $\{\alpha_1, \dots, \alpha_n\}$, where each $\alpha_i = (\alpha_{i,x}, \alpha_{i,y})$, so that $\alpha_{i,x} < \alpha_{i+1,x}$ and $\alpha_{i,y} > \alpha_{i+1,y}$, the points which do not meet both conditions, are skipped; more over α_1 has the smallest possible y coordinate.
2. Then

$$|\mathcal{C}_{00}^A| = \sum_{i=1}^{n-1} (\alpha_{i+1,x} - \alpha_{i,x}) \alpha_{i,y}$$

Figure 5 shows how points in \mathcal{C}_{00}^A are broken up into rectangles, and their size added up in step 2.

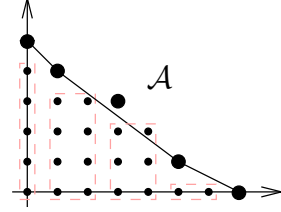

Figure 5: Computing size of \mathcal{C}_{00}^A

Similar procedures can be given to compute $|\mathcal{C}_{01}^A|$, $|\mathcal{C}_{10}^A|$, and $|\mathcal{C}_{11}^A|$; starting points and appropriate sorting directions are different.

Thus, for an unmixed bivariate polynomial system, it can be predicted exactly from the support, whether or not the Dixon method computes the resultant exactly, and if not, what the degree of the extraneous factor is. It should also be possible to say what coefficients of the terms in the polynomial appear in the extraneous factor as well as their degree.

6 Dixon Multiplier Matrix

As the reader would have noticed, the Dixon matrix above has, in general, complex entries; unlike in the Sylvester, Macaulay and sparse resultant formulations, where matrix entries are either zeros or coefficients of terms appearing in a polynomial system, entries in the Dixon matrix are determinants of the coefficients. For the bivariate case, entries are 3×3 determinants.

In [CK00b], we were able to settle an open problem about the Dixon resultant formulation. We proposed a method for constructing Sylvester-type resultant matrices based on the Dixon formulation. Below, we review a generalization of that construction which has been recently developed; more details can be found in [CK02]. We also show a relationship between these matrices and the Dixon matrices. The results in the previous section about the relationship between the support of the Dixon polynomial and the support of the polynomial system can be applied to the size of the Dixon multiplier matrices case as well.

The construction below is given first for the general case of d variables. In general, let m be any monomial. The Dixon polynomial can be rewritten as

$$m \theta(f_0, \dots, f_d) = \sum_{i=0}^d f_i \theta_i(m) \quad \text{where} \quad \theta_i(m) = \theta(f_0, \dots, f_{i-1}, m, f_{i+1}, \dots, f_d) = \bar{X} \Theta_i X_i.$$

In section 3, Dixon polynomial was expressed thru Dixon matrix as $\theta(f_0, \dots, f_d) = \bar{X} \Theta X$. Putting both expressions for Dixon polynomial together, we get

$$\begin{aligned} m \theta(f_0, \dots, f_d) &= m \bar{X} \Theta X = \bar{X} \Theta m X = \sum_{i=0}^d f_i \theta_i(m) = \sum_{i=0}^d f_i \bar{X} \Theta_i X_i \\ &= \bar{X} \sum_{i=0}^d \Theta_i (X_i f_i) = \bar{X} (\Theta_0 : \Theta_1 : \dots : \Theta_d) \begin{pmatrix} X_0 f_0 \\ X_1 f_1 \\ \vdots \\ X_d f_d \end{pmatrix} \end{aligned}$$

The above matrix can also be written as:

$$\bar{X} (T \times M) X',$$

where $T = (\Theta_0 : \Theta_1 : \dots : \Theta_d)$ and $M \times X'$ is the Dixon multiplier matrix constructed from $(X_i f_i)$ for $i = \{0, \dots, d\}$.

It is proved in [CK00b] that the matrix M is a Sylvester-type resultant matrix with entries 0 and coefficients of terms in polynomials in \mathcal{F} . Further, a projection operator can be extracted as the determinant of a rank submatrix of M [KSY94].³ The matrix T is called the *transformation* matrix, and it relates the Dixon matrix to the associated Sylvester-type matrix (called the sparse Dixon matrix in [CK00b] and called the Dixon multiplier matrix in this paper). The set X_i of terms is a multiplier set for f_i .

It is shown in [CK02] that for an unmixed polynomial system \mathcal{F} with support \mathcal{A} , if $S_{\mathbf{x}}(m) \in \overline{\mathcal{A}}$ (recall that $\overline{\mathcal{A}}$ is the union of \mathcal{A} and all support-interior points of \mathcal{A}), then

$$S_{\mathbf{x}}(\theta) = S_{\mathbf{x}}(\theta_i(m)), \quad \text{for } i = 0, \dots, d.$$

Further, the multiplier set X_i for f_i is obtained from $\theta_i(m)$; in fact, $S_{\mathbf{x}}(X_i) = S_{\mathbf{x}}(\theta_i(m))$. For the unmixed case, $S_{\mathbf{x}}(X_i)$ is the same for each $i = 0, \dots, d$; it is denoted by \mathcal{X} . Thus, in the case of a generic unmixed polynomial system, any m from $\overline{\mathcal{A}}$ can be used for constructing a Dixon multiplier matrix. For convenience, the least degree monomial m in $\overline{\mathcal{A}}$ is picked. In section 7, where mixed polynomial systems are discussed, it is shown that the choice of m becomes crucial for generating **good** Dixon multiplier matrices leading to resultants or projection operators with extraneous factors of low degree.

It is shown in [CK00b] and [CK02] that

Theorem 6.1 *For a given polynomial system \mathcal{F} , if its Dixon matrix is exact (in the sense, that the resultant of \mathcal{F} is the determinant of the Dixon matrix), then the associated Dixon multiplier matrix is exact as well.*

For the bivariate case, the determinant of the Dixon matrix is the same, irrespective of the variable ordering used in constructing the Dixon polynomial. It is, however, possible to construct two different Dixon multiplier matrices based on different variable orderings. The two multiplier sets are:

$$\mathcal{X}_1 = \Delta_{\mathcal{B}_{\mathcal{A}}}^{x,y} / \langle \mathcal{C}_{00}^{\mathcal{A}}, \mathcal{C}_{01}^{\mathcal{A}}, \mathcal{C}_{10}^{\mathcal{A}}, \mathcal{C}_{11}^{\mathcal{A}} \rangle \quad \text{or} \quad \mathcal{X}_2 = \Delta_{\mathcal{B}_{\mathcal{A}}}^{y,x} / \langle \mathcal{C}_{00}^{\mathcal{A}}, \mathcal{C}_{01}^{\mathcal{A}}, \mathcal{C}_{10}^{\mathcal{A}}, \mathcal{C}_{11}^{\mathcal{A}} \rangle,$$

where $\Delta_{\mathcal{B}_{\mathcal{A}}}^{x,y} = \Delta_{\mathcal{B}_{\mathcal{A}}}$ discussed in the previous section, and $\Delta_{\mathcal{B}_{\mathcal{A}}}^{y,x}$ is the set constructed in the same way as $\Delta_{\mathcal{B}_{\mathcal{A}}}$ except that the role of x and y is reversed.

For the unmixed generic bivariate case, if the size of the multiplier set $|\mathcal{X}| = \mu(\mathcal{A}, \mathcal{A}) = 2\text{Vol}(\mathcal{A})$, then the Dixon matrix is exact, implying that its determinant is the resultant. In that case, the Dixon multiplier matrix is also exact.

From the above theorem and Theorem 4.4 in the previous section, we have one of the main results of the paper:

Theorem 6.2 *For a generic unmixed bivariate polynomial system \mathcal{F} with support \mathcal{A} and support complement $\mathcal{C}_{\mathcal{A}} = \mathcal{C}_{00}^{\mathcal{A}} \cup \mathcal{C}_{01}^{\mathcal{A}} \cup \mathcal{C}_{10}^{\mathcal{A}} \cup \mathcal{C}_{11}^{\mathcal{A}}$, the Dixon multiplier matrix M is exact if and only if each $\mathcal{C}_{i,j}^{\mathcal{A}}$ is rectangular.*

6.1 Zhang and Goldman's Corner Cut Supports

In [ZG00, Zha00], Zhang and Goldman proposed a method to construct Sylvester-type matrices for the bivariate case. Below, we show how their results follow from our general result above. As will be shown below, our result is stronger since it gives a necessary and sufficient condition on bivariate supports.

Zhang and Goldman [ZG00] defined a *corner-cut* support as a support obtained from a bi-degree support after removing rectangular corners.

Definition 6.1 *A support \mathcal{A} is called **corner-cut** if $\mathcal{A} = \mathcal{B}_{\mathcal{A}} / \langle \mathcal{C}_{00}^{\mathcal{A}}, \mathcal{C}_{01}^{\mathcal{A}}, \mathcal{C}_{10}^{\mathcal{A}}, \mathcal{C}_{11}^{\mathcal{A}} \rangle$ and each $\mathcal{C}_{i,j}^{\mathcal{A}}$ is rectangular.*

³In [CK00b], the monomial 1 is used for the construction of the Dixon multiplier matrices, which are called **sparse Dixon** matrices in [CK00b]. The above construction is a generalization of the construction in [CK00b]. This generalization turns out to be particularly useful for constructing "good" Dixon multiplier matrices for mixed polynomial systems; the determinants of such multiplier matrices have smaller degree extraneous factors in the associated projection operators.

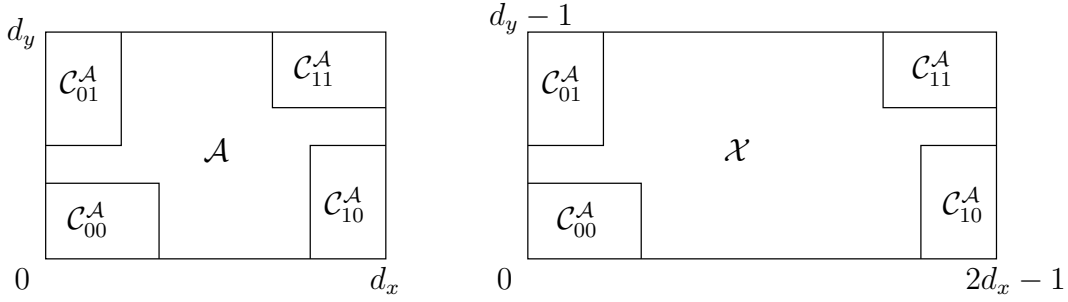

Figure 6: Corner cut support \mathcal{A} and multiplier set \mathcal{X} as in [Zha00]

Note that above definition requires that not only $\mathcal{C}_{i,j}^{\mathcal{A}}$ be rectangular, but also \mathcal{A} contain all of the support interior points.

For an unmixed bivariate polynomial system with a corner-cut support \mathcal{A} , Zhang and Goldman proposed to use the following multipliers to construct the resultant matrix

$$\mathcal{X} = \Delta_{\mathcal{B}_{\mathcal{A}}}^{y,x} / \langle \mathcal{C}_{00}^{\mathcal{A}}, \mathcal{C}_{01}^{\mathcal{A}}, \mathcal{C}_{10}^{\mathcal{A}}, \mathcal{C}_{11}^{\mathcal{A}} \rangle.$$

In figure 6, the support \mathcal{A} and the multiplier set \mathcal{X} used by Zhang and Goldman are shown. The Minkowski sum (whose points correspond to the columns of the resultant matrix) is shown in Figure 7. In particular,

$$\begin{aligned} |\mathcal{X}| &= |\Delta_{\mathcal{B}_{\mathcal{A}}}^{y,x}| - |\mathcal{C}_{00}^{\mathcal{A}}| - |\mathcal{C}_{01}^{\mathcal{A}}| - |\mathcal{C}_{10}^{\mathcal{A}}| - |\mathcal{C}_{11}^{\mathcal{A}}| = 2 \text{Vol}(\mathcal{A}) \quad \text{and} \\ |\mathcal{A} + \mathcal{X}| &= 3|\Delta_{\mathcal{B}_{\mathcal{A}}}| - 3|\mathcal{C}_{00}^{\mathcal{A}}| - 3|\mathcal{C}_{01}^{\mathcal{A}}| - 3|\mathcal{C}_{10}^{\mathcal{A}}| - 3|\mathcal{C}_{11}^{\mathcal{A}}| = 3|\mathcal{X}|. \end{aligned}$$

The matrix defined by Zhang and Goldman's construction is square, and its size is exact in the sense that each polynomial appears in the matrix as many times as the number of toric roots of the other 2 polynomials. It was shown in [ZG00] that these matrices are nonsingular in the generic case. Hence, their determinant is the resultant.

A corner-cut support \mathcal{A} satisfies the condition in Theorem 5.2, giving

Corollary 6.2.1 *Given a generic unmixed polynomial system \mathcal{F} with a corner-cut support \mathcal{A} , the determinant of the Dixon multiplier matrix constructed using multipliers from \mathcal{X} is its resultant.*

It is also possible to use the multipliers

$$\mathcal{X}' = \Delta_{\mathcal{B}_{\mathcal{A}}}^{x,y} / \langle \mathcal{C}_{00}^{\mathcal{A}}, \mathcal{C}_{01}^{\mathcal{A}}, \mathcal{C}_{10}^{\mathcal{A}}, \mathcal{C}_{11}^{\mathcal{A}} \rangle$$

giving the exact resultant.

The condition in Theorem 5.2 is weaker than the one required by Zhang and Goldman. Even if the support \mathcal{A} of a generic unmixed bivariate polynomial system is not corner-cut, but the support $\overline{\mathcal{A}}$ which includes \mathcal{A} and its support-interior points is corner-cut, even then the resultant can be computed exactly using the Dixon multiplier matrix construction. Furthermore, this is a necessary and sufficient condition for the determinant of the associated Dixon multiplier matrix to be the resultant.

Another immediate corollary of this result is that if \mathcal{A} is such that $\overline{\mathcal{A}}$ is not corner-cut, the determinant of the Dixon multiplier matrix constructed using multipliers from \mathcal{X} (or \mathcal{X}') is a nontrivial multiplier of its resultant (in other words, there is an extraneous factor).

The notion of a corner-cut support cannot be naturally extended to polynomial systems with more than two variables, as corner cut construction does not yield exact matrices for some simple 3 dimensional supports. For example, an unmixed polynomial system with support $\{(0, 0, 0), (1, 0, 0), (0, 1, 0), (0, 0, 2), (1, 0, 2), (0, 1, 2)\}$ can be said to be corner-cut, as the rectangular corner is missing at points $(1, 1, 0), (1, 1, 1)$ and $(1, 1, 2)$, yet the Dixon multiplier matrix will result in extraneous factors, if care is not taken to choose appropriate variable order while constructing Dixon polynomial. This raises an interesting open question: given a corner-cut support in 3 dimensions (generalized in the natural way), does there always exist a variable order making the Dixon multiplier matrix exact?

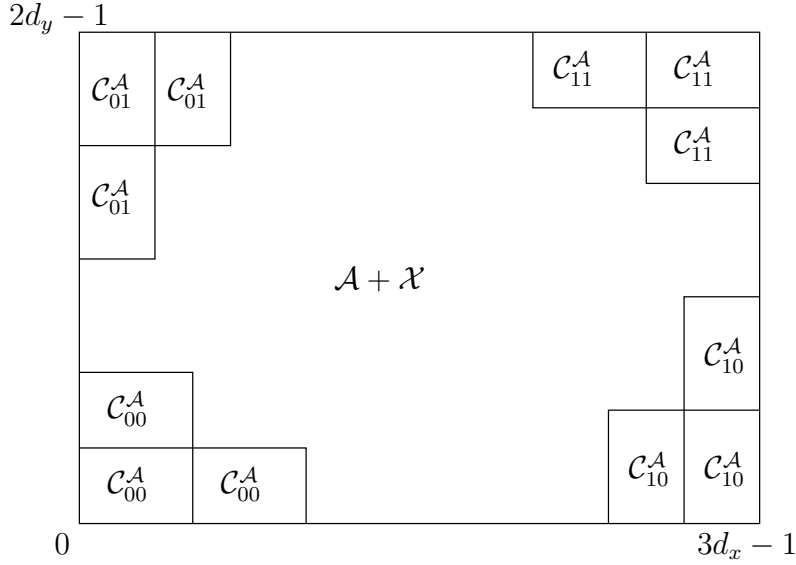

Figure 7: The Minkowski Sum $\mathcal{A} + \mathcal{X}$ as in [Zha00]

7 Mixed Polynomial Systems

We show below that the Dixon multiplier matrix construction is especially effective for mixed polynomial systems. This construction depends upon on generating multiplier sets for each polynomial, and is determined by the presence (or absence) of monomials in the support of the polynomials in the polynomial system. As should be evident from the above discussion, the multiplier sets determine the size of the Dixon multiplier matrix and hence, the degree of a projection operator.

Consider a mixed, generic polynomial bivariate system $\mathcal{F} = \{f_0, f_1, f_2\}$:

$$f_0 = \sum_{\alpha \in \mathcal{A}_0} a_{i,j} x^{\alpha_x} y^{\alpha_y}, \quad f_1 = \sum_{\beta \in \mathcal{A}_1} b_{i,j} x^{\beta_x} y^{\beta_y}, \quad f_2 = \sum_{\gamma \in \mathcal{A}_2} c_{i,j} x^{\gamma_x} y^{\gamma_y},$$

where \mathcal{A}_i is a support of f_i .

In mixed cases, the construction of a **good** Dixon multiplier matrix (in the sense that its determinant gives the projection operator that has the least degree extraneous factor) is sensitive to the choice of m in the construction which influences the support of $\theta_i(m)$ and hence, the multiplier set for each f_i . Choosing an appropriate m can be formulated as an optimization problem.

For any given support point $\alpha = (\alpha_x, \alpha_y)$, let $m = x^{\alpha_x} y^{\alpha_y}$, then

$$S_{\mathbf{x}}(\theta_0(m)) = \Delta_{\langle \{\alpha\}, \mathcal{A}_1, \mathcal{A}_2 \rangle}, S_{\mathbf{x}}(\theta_1(m)) = \Delta_{\langle \mathcal{A}_0, \{\alpha\}, \mathcal{A}_2 \rangle}, S_{\mathbf{x}}(\theta_2(m)) = \Delta_{\langle \mathcal{A}_0, \mathcal{A}_1, \{\alpha\} \rangle}.$$

Let $\Phi_0(\alpha) = |\Delta_{\langle \{\alpha\}, \mathcal{A}_1, \mathcal{A}_2 \rangle}|$, $\Phi_1(\alpha) = |\Delta_{\langle \mathcal{A}_0, \{\alpha\}, \mathcal{A}_2 \rangle}|$ and $\Phi_2(\alpha) = |\Delta_{\langle \mathcal{A}_0, \mathcal{A}_1, \{\alpha\} \rangle}|$.

Since $\Phi_i(\alpha)$ represents the number of rows corresponding to polynomial f_i in the Dixon multiplier matrix, the goal is to find α such that

$$\Phi(\alpha) = \Phi_0(\alpha) + \Phi_1(\alpha) + \Phi_2(\alpha)$$

is minimized; that is, the size of the entire Dixon matrix is minimized, so that smaller extraneous factor is produced. One can choose to minimize particular $\Phi_i(\alpha)$ in the hope having coefficients of f_i appearing with smallest degree in the projection operator.

Clearly minimizing α must belong to $\mathcal{B}_{\mathcal{A}}$, as the size $\Delta_{\mathcal{A}}$ will only increase for an α outside $\mathcal{B}_{\mathcal{A}}$.

7.1 Searching the Appropriate Monomial for Constructing Multiplier Matrix

A brute force method for finding an exponent vector that minimizes $\Phi(\alpha)$ is to compute its value for each point in $\mathcal{B}_{\mathcal{A}}$. One disadvantage of this method is that it depends upon the maximum and minimum values of exponents in the supports, which is (almost) the same as the degree of variables of the polynomials in the system.⁴ Even though this search is not likely to significantly affect the overall complexity of the resultant algorithm, it will be nice to have a method that depends on the size of the supports; in that case, polynomial systems with small supports can be easily handled.

We show below that the bounding box $\mathcal{B}_{\mathcal{A}}$ of supports can be partitioned into rectangular regions, called *cells*, such that each $\Phi_i(\alpha)$ is linear in the coordinates of $\alpha = (\alpha_x, \alpha_y)$ over a cell. The equation for each $\Phi_i(\alpha)$ changes from one cell to another.

Let $P = \mathcal{A}_0 \cup \mathcal{A}_1 \cup \mathcal{A}_2$ and $P = \{p_{i_1}, \dots, p_{i_n}\}$ be list of points sorted on x axis, and $P = \{p_{j_1}, \dots, p_{j_n}\}$ be list of points sorted on y axis.

Let $\mathcal{B}_{\mathcal{A}} = \mathcal{B}_u^v$. Split x axis into $2n + 1$ intervals I_1, \dots, I_{2n+1} ,

$$(u_x, p_{i_1,1}), [p_{i_1,x}, p_{i_1,x}], (p_{i_1,x}, p_{i_2,x}), \dots, (p_{i_{n-1},x}, p_{i_n,x}), [p_{i_n,x}, p_{i_n,x}], (p_{i_n,x}, v_x),$$

and similarly, split y axis into $2n + 1$ intervals J_1, \dots, J_{2n+1} ,

$$(u_y, p_{j_1,y}), [p_{j_1,y}, p_{j_1,y}], (p_{j_1,y}, p_{j_2,y}), \dots, (p_{j_{n-1},y}, p_{j_n,y}), [p_{j_n,y}, p_{j_n,y}], (p_{j_n,y}, v_y),$$

where (a, b) is an open interval containing integral points strictly greater than a and strictly less than b , and $[a, b]$ is a closed interval containing integral points greater than or equal to a and less than or equal to b . This splits $\mathcal{B}_{\mathcal{A}}$ into rectangular regions $R_{k,l}(P) = I_k \times J_l$ for $k, l \in \{1, \dots, 2n + 1\}$. Note every point of \mathcal{B}_u^v , belongs to only one region. Let $R_{k,l}(P)$ stand for the $(k, l)^{th}$ region of \mathcal{B}_u^v , based on P .

Theorem 7.1 $\Phi(\alpha)$ is linear in cell $R_{k,l}(P)$ for any $k, l \in \{1, \dots, 2n + 1\}$.

Proof: (Sketch) It suffices to show that each $\Phi_i(\alpha)$ is linear in $R_{k,l}(P)$. Below, we sketch the proof of linearity of Φ_0 ; proofs for Φ_1 and Φ_2 are similar.

From the definition of $R_{k,l}(P)$, it should be evident that the relative position of any $\alpha \in R_{k,l}(P)$ to the points of \mathcal{A}_1 and \mathcal{A}_2 does not change. One way to establish linearity is to subdivide all simplexes $\langle \alpha, \beta, \gamma \rangle$ where $\beta \in \mathcal{A}_1$ and $\gamma \in \mathcal{A}_2$ as in proposition 4.2, which also can be done on y coordinate. Since α is restricted to $R_{k,l}(P)$, most of the simplexes will not even change when α varies within the cell. It can be shown that rectangular regions generated by these simplexes will increase or decrease by same amount as coordinates of α are changed \square .

Given that the minimal value of a linear equation over a polyhedral is always at corners, it suffices to evaluate $\Phi(\alpha)$ at the corner of each cell.

The complexity of this algorithm is governed by the number of cells and the cost of evaluating $\Phi(\alpha)$. Number of cells is bounded by $(2n + 1)^2$, where n is the size of \mathcal{A} , the union of all supports. The evaluation cost of $\Phi(\alpha)$ is the sum of the evaluation cost of each $\Phi_i(\alpha)$ for $i = \{0, 1, 2\}$. The evaluation cost of each $\Phi_0(\alpha)$ is $O(n_1 n_2)$ where $n_1 = |\mathcal{A}_1|, n_2 = |\mathcal{A}_2|$. The overall complexity for finding α minimizing $\Phi(\alpha)$ is

$$O((2n + 1)^2(n_1 n_2 + n_0 n_2 + n_0 n_1)) = O(n^4).$$

As an example, consider the polynomial system shown in example 4 of the next section. Its support is:

$$\begin{aligned} \mathcal{A}_0 &= \{(1, 0), (0, 1)\}, \\ \mathcal{A}_1 &= \{(1, 1), (1, 2)\} \quad \text{and} \\ \mathcal{A}_2 &= \{(2, 1), (0, 1)\} \end{aligned}$$

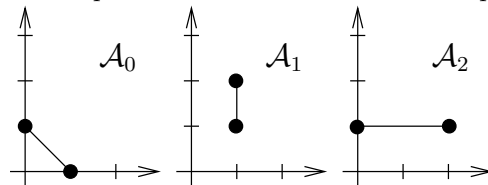

Figure 8: Support of example 4

⁴It is the same if there is a constant term in at least one polynomial.

The set $\mathcal{B}_{\mathcal{A}}$ has all the points with the maximum coordinate value of 2. Table 1 below shows all values $\Phi(\alpha)$ for $\alpha \in \mathcal{B}_{\mathcal{A}}$, as well for α outside $\mathcal{B}_{\mathcal{A}}$. Since this problem is easy for the Gröbner basis algorithm, its toric resultant can be obtained using Gröbner basis:

$$gb = a_{10}^2 c_{01} b_{12}^2 + c_{21} a_{01}^2 b_{11}^2,$$

It is thus possible to check the extraneous factors for choosing different α 's.

No	α	$\Phi_0(\alpha)$	$\Phi_1(\alpha)$	$\Phi_2(\alpha)$	$\Phi(\alpha)$	nCols	Rank	Extra Factor
1.	(0, 0)	4	3	3	10	10	9	$b_{11} a_{10}^2 c_{21}$
2.	(1, 0)	4	2	2	8	8	8	$a_{10}^2 c_{01}$
3.	(0, 1)	2	2	2	6	7	6	$-c_{21}$
4.	(2, 0)	4	3	4	11	11	10	$-a_{01} a_{10} c_{01} c_{21}^2$
5.	(1, 1)	2	2	1	5	5	5	1
6.	(0, 2)	3	4	2	9	8	8	$a_{01} b_{12} c_{21}$
7.	(3, 0)	5	4	6	15	14	12	$-a_{01}^3 c_{21}^3 c_{01}$
8.	(2, 1)	2	2	3	7	8	7	$-c_{21}^2$
9.	(1, 2)	2	4	1	7	7	7	$-b_{12}^2$
10.	(0, 3)	5	6	3	14	11	11	$a_{01}^2 a_{10} b_{11} b_{12} c_{21}$
11.	(4, 0)	6	5	8	19	17	15	$-a_{01}^4 b_{11} c_{21}^4 c_{01}$
12.	(3, 1)	3	3	5	11	12	10	$-c_{21}^3 b_{11} a_{01}$
13.	(2, 2)	3	4	3	10	10	10	$-b_{12}^2 c_{21}^2 a_{10}$
14.	(1, 3)	4	6	2	12	10	10	$-b_{11} b_{12}^2 a_{01} a_{10}$
15.	(0, 4)	7	8	4	19	14	14	$a_{01}^4 b_{11} b_{12} c_{21}^2 a_{10}$

Table 1: Choice of α for the Dixon multiplier matrix of example 4.

The size of the exact resultant matrix is 5 as $\mu(\mathcal{A}_1, \mathcal{A}_2) = 2, \mu(\mathcal{A}_0, \mathcal{A}_2) = 2$ and $\mu(\mathcal{A}_0, \mathcal{A}_1) = 1$; hence, optimal $\Phi_0(\alpha) = 2, \Phi_1(\alpha) = 2$ and $\Phi_2(\alpha) = 1$. From the table $\alpha = (1, 1)$ satisfies such condition.

Note that in the extraneous factor column, the degree of the coefficients from f_i is $\Phi_i(\alpha) - \mu_i(\mathcal{A})$ in general, where $\mu_i(\mathcal{A}) = \mu(\mathcal{A}_0, \dots, \mathcal{A}_{i-1}, \mathcal{A}_{i+1}, \dots, \mathcal{A}_d)$ where d is number of variables. In case the matrix is singular, the degree of the extraneous factor can be smaller depending upon the maximal minor selected from the resultant matrix.

8 Examples

In this section, we discuss a family of bivariate systems discussed in the literature [DE01a], and the performance of different algorithms in generating resultant matrices. Details of the examples are given after the table. The column *deg R* gives the degree of the resultant. Each method is identified by the paper in which it appeared. The last two columns are for the two methods based on the Dixon formulation discussed in this paper. The column labelled $|\Delta_{\mathcal{A}}|$ gives the size of the Dixon matrix. The reader should recall that the matrix entries are 3x3 determinants expressed in coefficients of terms in the polynomials. For other methods, matrix entries are mostly zeros or coefficients of terms in the polynomials. The last column in the table is the size of the Dixon multiplier matrix. For unmixed cases, the size of the Dixon multiplier matrix is 3 times the size of the Dixon matrix.

In the last column, if there is * next to the entry, this indicates that the algorithm in section 6 for generating the Dixon multiplier matrix by choosing an appropriate monomial was used instead of treating the problem as though it was unmixed by considering the union of the supports of the polynomials.

The degree of projection operators (hence extraneous factors) cannot be determined from the matrix sizes in the case of [CDS98], [DE01a] as well as the Dixon matrix (the $\Delta_{\mathcal{A}}$ column) as some of the matrix entries

Ex.	deg R	[CE00]	[CDS98]	[ZG00]	[DE01a]	$ \Delta_{\mathcal{A}} $	$\Phi(\alpha)$
1	$3n^2$	$\frac{3}{2}n(3n-1)$	$6n^2 - 9n + 4$	$\frac{21}{4}n^2$	$\frac{9}{2}n(n-1)+1$	$\frac{1}{2}n(3n-1)$	$\frac{3}{2}n(3n-1)$
2	$6n_1n_2$	$9n_1n_2$	$12n_1n_2 - 6(n_1+n_2)+4$	$6n_1n_2$	$9n_1n_2 - 3(n_1+n_2)+1$	$2n_1n_2$	$6n_1n_2$
3	12	15	10	12	10	4	12
4	5	5	4	6	4	2	5^*
5	7	12	7	15	7	4	7^*
6	18	26	22	18	19	6	18
7	24	35	34	30	22	8	24^*
8	57	92	97	63	64	20	60

Table 2: Comparison of resultant matrices

are different from coefficients of terms in polynomials. For the Dixon matrix, the degree of projection operator is $3|\Delta_{\mathcal{A}}|$; for the methods in [CDS98] and [DE01a], the degree of the projection operator is 2 more than the matrix size.

From the table, it is clear that the Dixon multiplier matrix method produces smaller extraneous factors; in almost all examples, it computes the resultant exactly. The method also turns out to be computationally less expensive for extracting a projection operator.

1. **Homogeneous** (unmixed) polynomial system of degree n

$$f_0(x, y) = \sum_{i+j \leq n} a_{ij}x^i y^j, \quad f_1(x, y) = \sum_{i+j \leq n} b_{ij}x^i y^j, \quad f_2(x, y) = \sum_{i+j \leq n} c_{ij}x^i y^j.$$

The mixed volume of any two polynomials is n^2 , the Bezout bound. The degree of the resultant is $3n^2$.

2. **Bi-homogeneous** (unmixed, corner cut) polynomial system of degree n_1, n_2 :

$$f_0(x, y) = \sum_{i=0}^{n_1} \sum_{j=0}^{n_2} a_{ij}x^i y^j, \quad f_1(x, y) = \sum_{i=0}^{n_1} \sum_{j=0}^{n_2} b_{ij}x^i y^j, \quad f_2(x, y) = \sum_{i=0}^{n_1} \sum_{j=0}^{n_2} c_{ij}x^i y^j.$$

The mixed volume of any two polynomials is $2n_1n_2$. The degree of the resultant is $6n_1n_2$.

3. **Examples from [CDS98]** (unmixed, corner cut)

$$\begin{aligned} f_0(x, y) &= a_{00} + a_{01}y + a_{10}x + a_{11}xy + a_{12}xy^2 + a_{13}xy^3, \\ f_1(x, y) &= b_{00} + b_{01}y + b_{10}x + b_{11}xy + b_{12}xy^2 + b_{13}xy^3, \\ f_2(x, y) &= c_{00} + c_{01}y + c_{10}x + c_{11}xy + c_{12}xy^2 + c_{13}xy^3. \end{aligned}$$

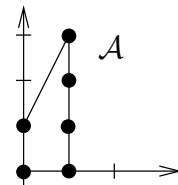

Figure 9: Support of example 3

This problem is given as an example in [CDS98], of the Chow form of a Hilzebruch surface. It is an unmixed problem, where any two polynomials have the mixed volume of 4. Notice that this problem has a corner-cut support.

4. **Example from [ZG00]** (mixed) This example appeared before in section 7. It was used as example in [DE01a] and [ZG00].

$$f_0(s, t) = 2s + t, \quad f_1(s, t) = st + st^2, \quad f_2 = s^2t + 2t.$$

The mixed volume is $[2, 2, 1]$ (i.e., $\mu(\mathcal{A}_1, \mathcal{A}_2) = 2$, $\mu(\mathcal{A}_0, \mathcal{A}_2) = 2$ and $\mu(\mathcal{A}_0, \mathcal{A}_1) = 1$). The degree of the resultant is 5.

5. **Example from [Man92]** (Mixed)

$$\begin{aligned} f_0(x, y) &= a_{10}x + a_{20}x^2 + a_{01}y \\ f_1(x, y) &= b_{10}x + b_{02}y^2 + b_{01}y \\ f_2(x, y) &= c_{10}x + c_{11}xy + c_{01}y. \end{aligned}$$

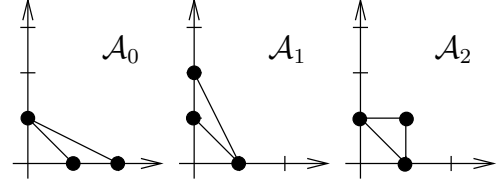

Figure 10: Support of example 5

This problem is about surface parameterization [Man92] Its BKK bound is $[2, 2, 3] = 7$.

6. **Example from [DE01b]** (unmixed, corner cut)

$$\begin{aligned} f_0 &= a_{00} + a_{10}x + a_{01}y + a_{12}xy^2 + a_{21}x^2y + a_{22}x^2y^2, \\ f_1 &= b_{00} + b_{10}x + b_{01}y + b_{12}xy^2 + b_{21}x^2y + b_{22}x^2y^2, \\ f_2 &= c_{00} + c_{10}x + c_{01}y + c_{12}xy^2 + c_{21}x^2y + c_{22}x^2y^2. \end{aligned}$$

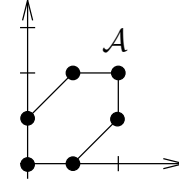

Figure 11: Support of example 6

The mixed volume of any two polynomials is 6, therefore resultant degree is 18. Moreover the problem is unmixed and corner-cut; therefore, the Dixon method, Dixon multiplier matrix and [ZG00] have exact matrices for this problem.

It was included in [DE01b] and is interesting because hybrid method proposed in that paper does not produce an exact matrix.

7. **Example from [GS01]** (mixed)

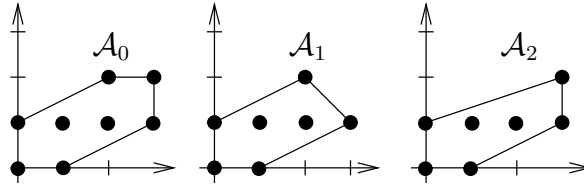

Figure 12: Support of example 7

$$\begin{aligned} f_0 &= a_{00} + a_{10}x + a_{01}y + a_{11}xy + a_{21}x^2y + a_{22}x^2y^2 + a_{31}x^3y + a_{32}x^3y^2, \\ f_1 &= b_{00} + b_{10}x + b_{01}y + b_{11}xy + b_{21}x^2y + b_{22}x^2y^2 + b_{31}x^3y, \\ f_2 &= c_{00} + c_{10}x + c_{01}y + c_{11}xy + c_{21}x^2y + c_{31}x^3y + c_{32}x^3y^2. \end{aligned}$$

This polynomial system is defined in [GS01] to study the self intersections of parameterized surface. Interestingly this problem has the BKK bound of $[8, 8, 8] = 24$, which is the same as though this system was unmixed, where support of the first polynomial is the union of the support of the other two polynomials.

8. **Example from [DE01a]** (unmixed)

$$\begin{aligned}
f_0(x, y) &= a_{10}x + a_{21}x^2y + a_{03}y^3 + a_{15}xy^5 + a_{25}x^2y^5 + a_{33}x^3y^3 + a_{34}x^3y^4, \\
f_1(x, y) &= b_{10}x + b_{21}x^2y + b_{03}y^3 + b_{15}xy^5 + b_{25}x^2y^5 + b_{33}x^3y^3 + b_{34}x^3y^4, \\
f_2(x, y) &= c_{10}x + c_{21}x^2y + c_{03}y^3 + c_{15}xy^5 + c_{25}x^2y^5 + c_{33}x^3y^3 + c_{34}x^3y^4.
\end{aligned}$$

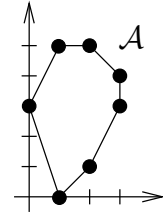

Figure 13: Support of example 8

This example appeared in [DE01a] as a demonstration for the hybrid method proposed in that paper for bivariate systems. The mixed volume of any two polynomials is 19; hence, the resultant degree is 57.

9 Future Work

We have been able to identify necessary and sufficient conditions on the support of an unmixed polynomial system such that the methods based on the Dixon resultant formulation can compute the resultant of such a polynomial system exactly. When this cannot be done, the degree of the projection operator can be predicted, from which the degree of the extraneous factor appearing in it can be computed. This still does not lead to precisely identifying the extraneous factor as in the case of eliminating a single variable. We plan to investigate this issue next.

For non-generic polynomial systems for which the number of toric roots is still the BKK bound, the degree of extraneous factor in a projection operator cannot be estimated. It appears that the discrepancy between the BKK bound and the size of Dixon matrix is due to the difference in volume of the Newton polytope and the size of the corresponding support. Experimental evidence suggests that the coefficients of terms in polynomials also play a role in determining the support of the Dixon polynomial; this is also reflected in the formula for the Dixon polynomial based on the Cauchy-Binet formula. We are interested in analyzing whether the genericity requirements for obtaining the BKK bound is sufficient to preclude any role the coefficients of terms in a polynomial system play in determining the support of the Dixon polynomial and hence, the size of Dixon matrix.

The focus of this paper has been on bivariate systems. We are interested in generalizing these results – particularly the notion of a support-interior point in an arbitrary dimension. It can be shown that the determinant of the Dixon multiplier matrix is not exactly the resultant for a tri-variate generic unmixed system even if its support is corner-cut.⁵ However, a necessary and sufficient condition on supports based on exclusion of support-interior points seems plausible.

References

- [CDS98] E. Cattani, A. Dickenstein, and B. Sturmfels. Residues and resultants. *J. Math. Sci. Univ. Tokyo*, 5:119–148, 1998.
- [CE00] J.F. Canny and I.Z. Emiris. A subdivision based algorithm for the sparse resultant. *J. ACM*, 47:417–451, may 2000.
- [CK00a] A. D. Chthcerba and D. Kapur. Conditions for exact resultants using the Dixon formulation. *ISSAC 2000*, 2000.
- [CK00b] A. D. Chthcerba and D. Kapur. Extracting sparse resultant matrices from Dixon resultant formulation. *Proc. of 7th Rhine Workshop (RCWA '00)*, pages 167–182, 2000.
- [CK02] A. D. Chthcerba and D. Kapur. Analysis of the Dixon resultant formulation based on support of a polynomial system. *In preparation*, 2002.

⁵The notion of a corner-cut support is assumed to be generalized to arbitrary dimensions in an obvious way.

- [CLO98] D. Cox, J. Little, and D. O’Shea. *Using Algebraic Geometry*. Springer-Verlag, New York, first edition, 1998.
- [DE01a] C. D’Andrea and I. Emiris. Hybrid sparse resultant matrices for bivariate systems. In B. Mourrain, editor, *ISSAC*, pages 24–31, London, Ontario, Canada, 2001. ACM Press.
- [DE01b] C. D’Andrea and I. Emiris. Hybrid sparse resultant matrices in small dimension. *In preparation*, 2001.
- [Dix08] A.L. Dixon. The eliminant of three quantics in two independent variables. *Proc. London Mathematical Society*, 6:468–478, 1908.
- [GKZ94] I.M. Gelfand, M.M. Kapranov, and A.V. Zelevinsky. *Discriminants, Resultants and Multidimensional Determinants*. Birkhauser, Boston, first edition, 1994.
- [GS01] A. Galligo and M. Stillman. Self-intersection curves of parametrized surfaces. *Manuscript*, 2001.
- [KS96] D. Kapur and T. Saxena. Sparsity considerations in the Dixon resultant formulation. In *Proc. ACM Symposium on Theory of Computing*, Philadelphia, May 1996.
- [KSY94] D. Kapur, T. Saxena, and L. Yang. Algebraic and geometric reasoning using Dixon resultants. In *ACM ISSAC 94*, pages 99–107, Oxford, England, July 1994.
- [Man92] D. Manocha. *Algebraic and numeric techniques for modeling and robotics*. PhD thesis, Computer Science Div, UC Berkeley, 1992.
- [PS93] P. Pedersen and B. Sturmfels. Product formulas for resultants and chow forms. *Math. Zeitschrift*, 214:377–396, 1993.
- [Sax97] T. Saxena. *Efficient variable elimination using resultants*. PhD thesis, Department of Computer Science, State University of New York, Albany, NY, 1997.
- [ZG00] M. Zhang and R. Goldman. Rectangular corner cutting and sylvester \mathcal{A} -resultants. In Carlo Traverso, editor, *Proc. of the Intern. Symp. on Symbolic and Algebraic Computation*, pages 301–308, St. Andrews, Scotland, 2000. ACM Press.
- [Zha00] M. Zhang. *Topics in Resultants and Implicitization*. PhD thesis, Rice University, Dept. of Computer Science, May 2000.